

## Type IFP AQUAMIST Recessed Nozzle Fittings Industrial Fryer Protection

### General Description

The TYCO Type IFP AQUAMIST Recessed Nozzle Fittings are stainless steel fittings which house the TYCO Type AM10 and Type AM31 AQUAMIST Nozzles. These fittings are designed to accommodate the Type AM10 and AM31 nozzles for industrial fryer primary cooking area applications. The fitting and nozzle combination is integrated with a tethered cap assembly. The cap conceals the nozzle which separates from the fitting during system discharge but remains attached by a length of chain.

It is recommended that the end user be consulted with respect to the suitability of the materials of construction for any given corrosive environment. The effects of ambient temperature, concentration of chemicals, and gas/chemical velocity should be considered, at a minimum, along with the corrosive nature to which the nozzles may be exposed.

For further details on Type AM10 and Type AM31 nozzles, refer to Technical Data Sheets TFP2210 for Type AM10 Nozzle and TFP2202 for Type AM31 Nozzle.

#### NOTICE

*The Type IFP AQUAMIST Recessed Nozzle Fittings described herein must be installed and maintained in compliance with this document and with the applicable standards of the National Fire Protection Association, in addition to*

#### IMPORTANT

*Always refer to Technical Data Sheet TFP700 for the "INSTALLER WARNING" that provides cautions with respect to handling and installation of sprinkler systems and components. Improper handling and installation can permanently damage a sprinkler system or its components and cause the sprinkler to fail to operate in a fire situation or cause it to operate prematurely.*

*the standards of any authorities having jurisdiction. Failure to do so may impair the performance of these devices.*

*The design of individual watermist systems can vary considerably, depending on the characteristics and nature of the hazard and the basic purpose of the watermist system. Because of these variations, the design of watermist systems for fire protection must only be performed by experienced designers who thoroughly understand the limitations as well as capabilities of such systems.*

*The owner is responsible for maintaining their fire protection system and devices in proper operating condition. Contact the installing contractor or nozzle manufacturer with any questions.*

### Technical Data

#### Minimum Working Pressure

See specific application data sheet

#### Maximum Working Pressure

250 psi (17,2 bar)

#### Thread Connection

1/2 inch NPT

#### Finish

Stainless Steel

#### Physical Characteristics

Recessed IFP Fitting, 3/4 Inch Socket Weld . . . . . Stainless Steel  
Recessed IFP Fitting, 3/4 Inch NPT Threaded . . . . . Stainless Steel  
Cap Assembly . . . . . Stainless Steel



### Design Criteria

Obtain guidance for the design of a watermist system that utilizes the TYCO Type IFP AQUAMIST Recessed Nozzle Fittings from the Technical Services Department.

When installing the TYPE AM31 AQUAMIST Nozzle into either the Threaded or Socket-Weld fitting, it can be installed in the pendent or angular position. When installing the Type AM10 AQUAMIST Nozzle into either the Threaded or Socket-Weld Fitting, it can only be installed in the pendent position.

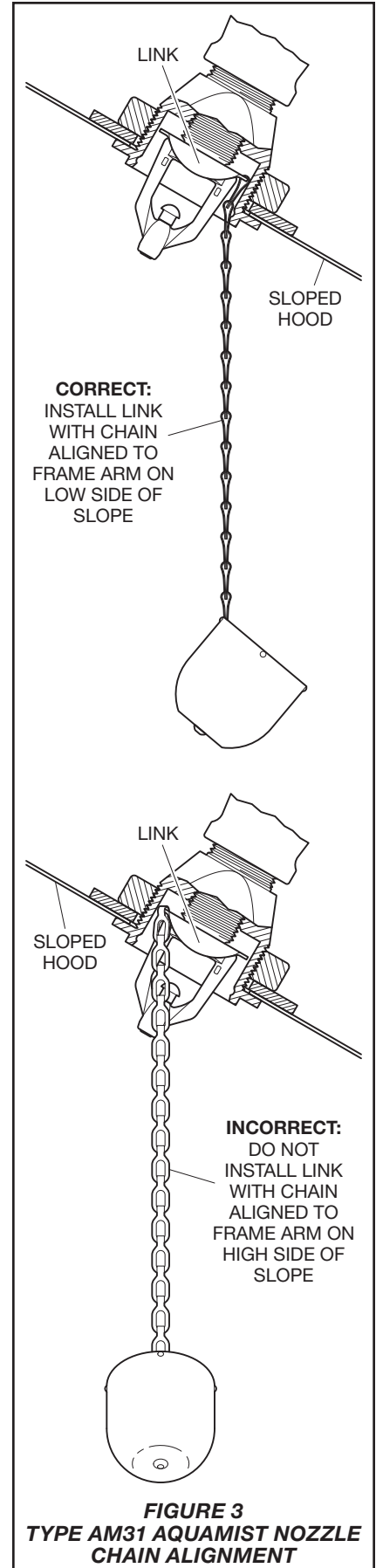
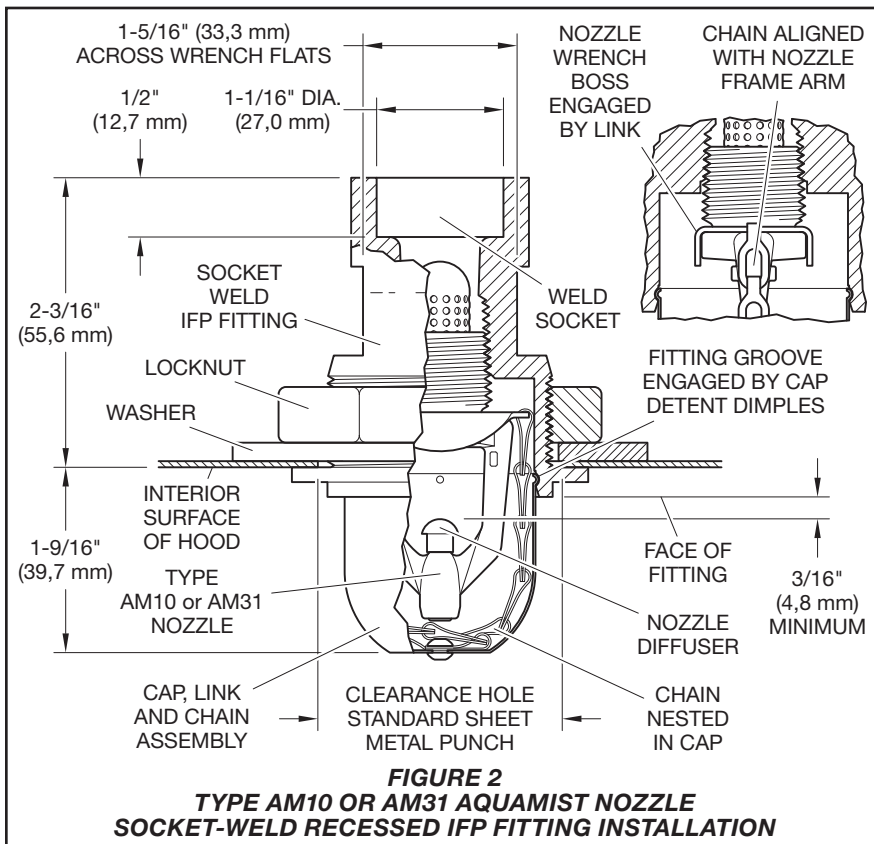
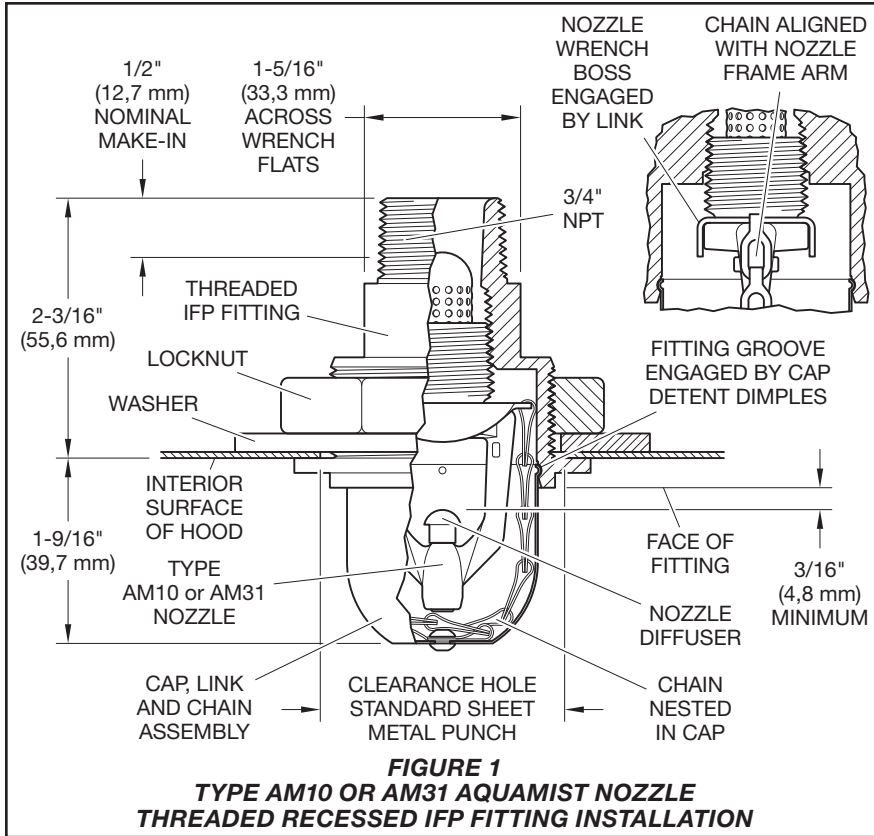

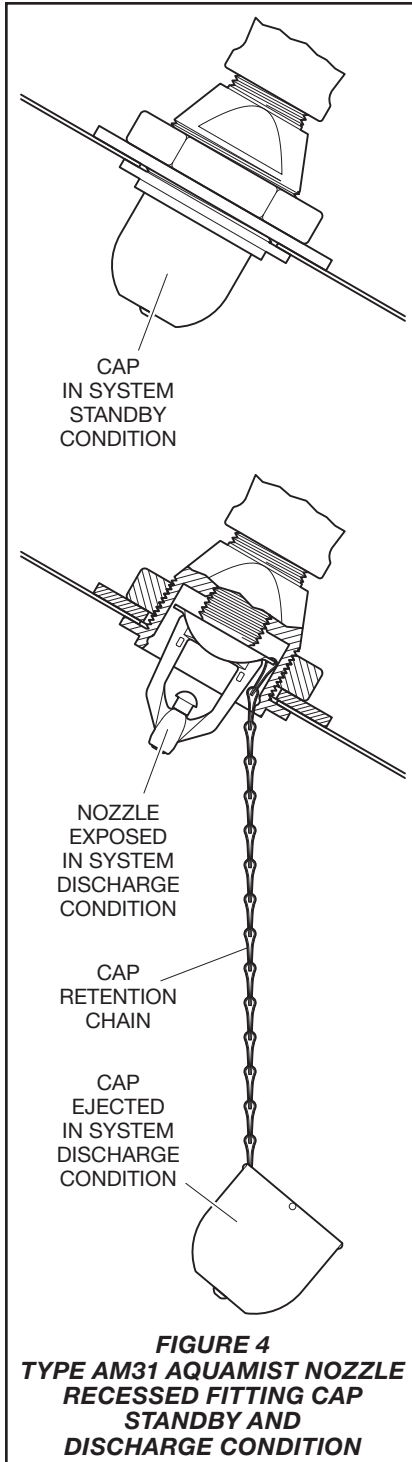

**FIGURE 4**  
**TYPE AM31 AQUAMIST NOZZLE**  
**RECESSED FITTING CAP**  
**STANDBY AND**  
**DISCHARGE CONDITION**

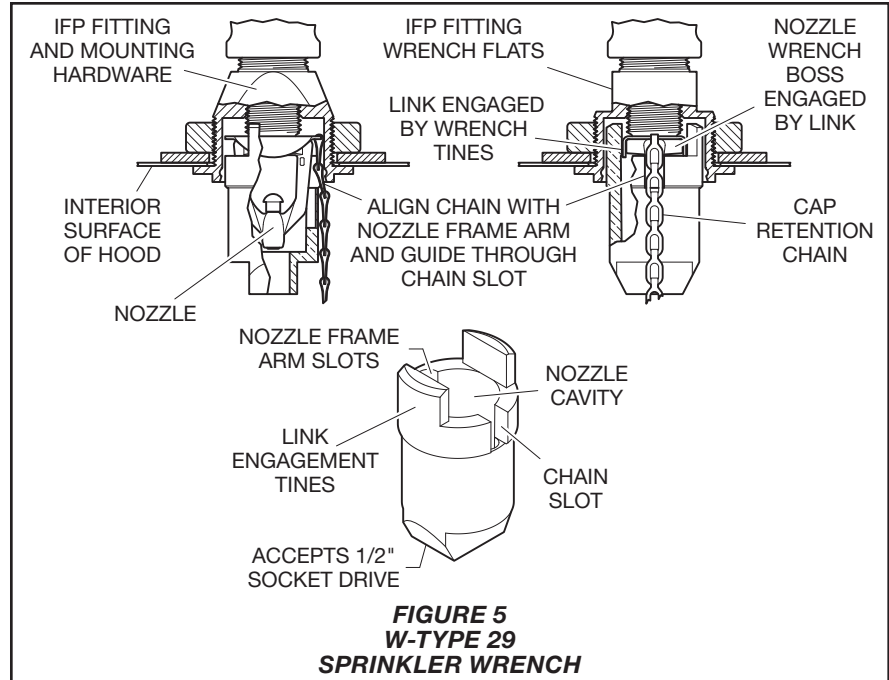

**FIGURE 5**  
**W-TYPE 29**  
**SPRINKLER WRENCH**

## Installation

The TYCO Type IFP AQUAMIST Recessed Nozzle Fittings must be installed in accordance with this section.

### General Instructions

A leak-tight 1/2 inch NPT Nozzle joint should be obtained by applying a minimum-to-maximum torque of 7 to 14 ft-lbs (9,5 to 19,0 Nm). Higher levels of torque can distort the nozzle inlet and cause leakage or impairment of the nozzle.

### NOTICE

*The Type AM10 or AM31 AQUAMIST Nozzle may be factory assembled with a Recessed IFP Fitting and Cap. If the nozzles have been pre-assembled, proceed to Step 5.*

**Step 1.** Prepare nozzle by applying TEFLON paste thread sealant to pipe threads.

**Step 2.** Assemble nozzle with Cap Assembly. Engage nozzle wrench boss by Link flanges shown in Figures 1 and 2.

**Step 3.** Hand tighten nozzle into IFP fitting until nozzle diffuser is located 3/16 inch (4,8 mm) minimum from face of fitting.

**Step 4.** Tighten nozzle into fitting using only W-Type 29 Wrench (Figure 5). Guide wrench arm slots over nozzle frame arms, guide Cap Retention Chain through wrench chain slot, and engage Link flanges by wrench tines.

### NOTICE

*The Recessed IFP Fitting and Cap may be factory assembled with a Type AM10 or AM31 AQUAMIST Nozzle. If pre-assembled, ensure the cap is dislodged from the fitting exposing the nozzle to facilitate proper orientation and alignment. Observe nozzle orientation and chain alignment notices preceding Step 7.*

**Step 5.** From equipment interior, insert IFP Fitting (NPT Threaded or Socket-Weld) through clearance hole until flange is flush against interior surface of hood and hold in place.

**Step 6.** Install one Washer and Locknut on 1-1/2 NPS threaded portion of fitting extending through exterior of hood. Tighten Locknut and ensure fitting flange is flush against interior surface of hood.

### NOTICE

*To facilitate effective nozzle tightening it may be necessary to immobilize the IFP fitting by applying appropriate wrench to fitting wrench flats.*

*For proper installation ensure the Nozzle Frame Arms are aligned per Technical Data Sheet TFP2240.*

*For proper installation ensure Cap Retention Chain is aligned with nozzle frame arm on low side of hood slope as applicable (Figures 3 and 4).*

**Step 7.** Insert the chain into the Cap and snap cap into IFP fitting. Ensure fitting groove is fully engaged by Cap dimples.

**Step 8.** Connect system pipe or fitting.

- Threaded Fitting Installations (Figure 1) - With TEFLON paste sealant applied to IFP Fitting pipe threads, connect system fitting. A leak-tight 3/4 inch NPT fitting joint should be obtained by applying minimum-to-maximum torque of 10 to 20 ft-lbs (13,4 to 26,8 Nm). Higher levels of torque can distort the Fitting inlet with consequent leakage of Fitting or impairment of Nozzle.
- Socket-Weld Fitting Installations (Figure 2) - Insert prepared end of 3/4 Inch system pipe into IFP Fitting weld socket until fully engaged. Weld full circumference of pipe at juncture with face of IFP Fitting weld socket.

## Care and Maintenance

The TYCO Type IFP AQUAMIST Recessed Nozzle Fittings must be maintained and serviced in accordance with this section.

Before closing a fire protection system main control valve for maintenance work on the fire protection system that it controls, obtain permission to shut down the affected fire protection system from the proper authorities and notify all personnel who may be affected by this action.

Type IFP AQUAMIST Recessed Nozzle Fittings must never be painted, plated, coated or altered in any way after leaving the factory; otherwise, the spray performance may be impaired.

Care must be exercised to avoid damage to the nozzles -before, during, and after installation. Nozzles damaged by dropping, striking, wrench twist/slip-page, or the like, must be replaced.

Frequent visual inspections are recommended to be initially performed for nozzles installed in potentially corrosive atmospheres to verify the integrity of the materials of construction and finish as they may be affected by the corrosive conditions present for a given installation. Thereafter, annual inspections per NFPA 25 are required.

The owner is responsible for the inspection, testing, and maintenance of their fire protection system and devices in compliance with this document, as well as with the applicable standards of the National Fire Protection Association (e.g., NFPA 25), in addition to the standards of any other authorities having jurisdiction. Contact the installing contractor or nozzle manufacturer with any questions.

Water spray fixed systems should be inspected, tested, and maintained by a qualified Inspection Service in accordance with local requirements and/or national codes

If the Cap does not remain in place on the Fitting, it is recommended that the Link/Cap Subassembly be replaced.

## Ordering Procedure

Contact your local distributor for availability. When placing an order, indicate the full product name and Part Number (P/N).

### Type AM31 Nozzle with Socket-Weld IFP Fitting and Cap Assembly

Specify: Type AM31 AQUAMIST Nozzle with Socket-Weld IFP Fitting and Cap Assembly, Stainless Steel, P/N 28228

### Type AM31 Nozzle with NPT Threaded IFP Fitting and Cap Assembly

Specify: Type AM31 AQUAMIST Nozzle with NPT Threaded IFP Fitting and Cap Assembly, Stainless Steel, P/N 28227

### Type AM10 Nozzle with Socket-Weld IFP Fitting and Cap Assembly

Specify: Type AM10 AQUAMIST Nozzle with Socket-Weld IFP Fitting and Cap Assembly, Stainless Steel, P/N 28243

### Type AM10 Nozzle with NPT Threaded IFP Fitting and Cap Assembly

Specify: Type AM10 AQUAMIST Nozzle with NPT Threaded IFP Fitting and Cap Assembly, Stainless Steel, P/N 28242

### Sprinkler Wrench

Specify: W-Type 29 Sprinkler Wrench, P/N 28241

## REPLACEMENT PARTS

### Link/Cap Subassembly

Specify: Link/Cap Subassembly, Stainless Steel, P/N 000028230

### Type AM31 AQUAMIST Nozzles

Specify: Type AM31 AQUAMIST Nozzle, Stainless Steel finish, P/N 28229

### Type AM10 AQUAMIST Nozzles

Specify: Type AM10 AQUAMIST Nozzle, Stainless Steel, P/N 49-207-0-001