

Type AM4 AQUAMIST Nozzle Non-Automatic (Open)

General Description

The TYCO Type AM4 AQUAMIST Nozzle is a stainless steel, open (non-automatic) nozzle intended for use with total compartment, engineered, water mist deluge systems. It is an intermediate pressure nozzle which utilizes a single fluid jet impinging on a diffuser to produce a spray having a range of water droplet sizes suitable for the extinguishment of Class B fires, as well as incidental Class A fires.

It is recommended that the end user be consulted with respect to the suitability of the materials of construction and finish for any given corrosive environment. The effects of ambient temperature, concentration of chemicals, and gas/chemical velocity, should be considered, at a minimum, along with the corrosive nature to which the nozzles may be exposed.

NOTICE

The TYCO Type AM4 AQUAMIST Nozzles described herein must be installed and maintained in compliance with this document, as well as with the applicable standards of the National Fire Protection Association, in addition to the standards of any other authorities having jurisdiction. Failure to do so may impair the performance of these devices.

IMPORTANT

Always refer to Technical Data Sheet TFP700 for the "INSTALLER WARNING" that provides cautions with respect to handling and installation of sprinkler systems and components. Improper handling and installation can permanently damage a sprinkler system or its components and cause the sprinkler to fail to operate in a fire situation or cause it to operate prematurely.

The design of individual watermist systems can vary considerably, depending on the characteristics and nature of the hazard and the basic purpose of the watermist system. Because of these variations, the design of watermist systems for fire protection must only be performed by experienced designers who thoroughly understand the limitations as well as capabilities of such systems.

The owner is responsible for maintaining their fire protection system and devices in proper operating condition. Contact the installing contractor or sprinkler manufacturer with any questions.

Technical Data

Minimum Working Pressure

See specific application data sheet

Maximum Working Pressure

250 psi (17,2 bar)

Discharge Coefficient

$K = 0.24 \text{ GPM/psi}^{1/2}$
($K = 3,5 \text{ LPM/bar}^{1/2}$)

Thread Connection

1/2 inch NPT

Physical Characteristics

Frame	Stainless Steel
Strainer	Stainless Steel
Orifice Insert	Stainless Steel
Diffuser	Stainless Steel
Dust Cap	Buna-N or Fluorosilicone

The smallest waterway (orifice) diameter of the Orifice Insert is nominally 0.091 inches (2,31 mm), and the diameter of the Inlet Strainer perforations are nominally 0.060 inches (1,52 mm).



Design Criteria

Obtain guidance for the design of a watermist system that utilizes the TYCO Type AM4 AQUAMIST Nozzle from the Technical Services Department.

Installation

The TYCO Type AM4 AQUAMIST Nozzle must be installed in accordance with this section:

General Instructions

A leak tight 1/2 inch NPT nozzle joint should be obtained with a torque of 7 to 14 ft-lbs (9,5 to 19,0 Nm). A maximum of 21 ft-lbs (28,5 Nm) of torque may be used to install nozzles with 1/2 NPT connections. Higher levels of torque may distort the nozzle inlet and cause leakage or impairment of the nozzle.

Step 1. With pipe thread sealant applied to the pipe threads, hand tighten the nozzle into the nozzle fitting.

Step 2. Tighten the nozzle into the nozzle fitting using only the W-Type 6 Sprinkler Wrench (Ref. Figure 2). With reference to Figure 1, the W-Type 6 Sprinkler Wrench is to be applied to the wrenching area.

Care and Maintenance

The TYCO Type AM4 AQUAMIST Nozzle must be maintained and serviced in accordance with this section.

Before closing a fire protection system main control valve for maintenance work on the fire protection system that it controls, permission to shut down the affected fire protection system must be obtained from the proper authorities and all personnel who may be affected by this action must be notified.

The Type AM4 AQUAMIST Nozzle must never be painted, plated, coated or altered in any way after leaving the factory; otherwise, the spray performance may be impaired.

Care must be exercised to avoid damage to the nozzles—before, during, and after installation. Nozzles damaged by dropping, striking, wrench twist/slippage, or the like, must be replaced.

Frequent visual inspections are recommended to be initially performed for nozzles installed in potentially corrosive atmospheres to verify the integrity of the materials of construction and finish as they may be affected by the corrosive conditions present for a given installation. Thereafter, annual inspections per NFPA 25 are required.

The owner is responsible for the inspection, testing, and maintenance of their fire protection system and devices in compliance with this document, as well as with the applicable standards of the National Fire Protection Association (e.g., NFPA 25), in addition to the standards of any authority having jurisdiction. Contact the installing contractor or sprinkler manufacturer with any questions.

It is recommended that automatic sprinkler systems be inspected, tested, and maintained by a qualified Inspection Service in accordance with local requirements and/or national codes.

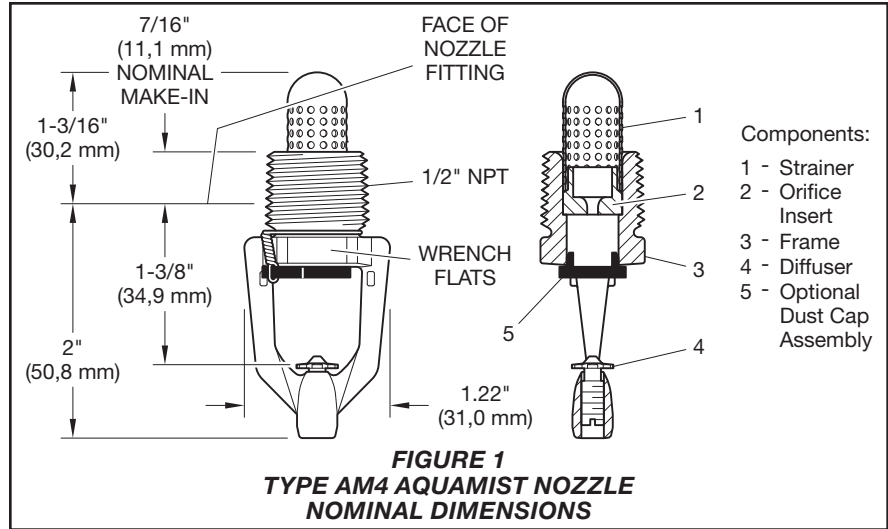

Ordering Procedure

Contact your local distributor for availability. When placing an order, indicate the full product name and P/N.

Type AM4 AQUAMIST Nozzle
 Specify: Type AM4 AQUAMIST Nozzle, Stainless Steel, P/N 49-204-0-001

Type AM4 AQUAMIST Nozzle with Dust Cap
 Specify: Type AM4 AQUAMIST Nozzle, Stainless Steel, with Buna-N Dust Cap, P/N 49-204-0-011

Specify: Type AM4 AQUAMIST Nozzle, Stainless Steel, with Fluorosilicone Dust Cap, P/N 28244

Sprinkler Wrench
 Specify: W-Type 6 Sprinkler Wrench, P/N 56-000-6-387

REPLACEMENT PARTS

Dust Cap Assembly
 Specify: Model F885 Dust Cap Assembly, Buna-N, with Stainless Steel Retention Wire*, P/N 56-885-0-001

Specify: Model F885 Dust Cap Assembly, Fluorosilicone, with Stainless Steel Retention Wire*, P/N 28247

* Refer to Technical Data Sheet TFP2299 for Installation Instructions

